

	VOLUME 240 (6)	JUNE 2010	ISSN 0029-5499
<h1>Nuclear Engineering and Design</h1>			
<b>An International Journal devoted to all aspects of Nuclear Fission Energy</b>			
Editor-in-Chief: Yassin Hassan Editors: Jason Chao Borut Mavko Dominique Bestion			
<b>Engineering Mechanics</b>			
Fast neutron fluence calculations as support for a BWR pressure vessel and internals surveillance program M.A. Lacortero, J.C. Palacios-Hernández, J. Ortiz-Villafuerte, J.V. Xolocostli-Munguía and A.M. Gómez-Torres			1271
Effect of prestress force on longitudinal vibration of bonded tendons embedded in a nuclear containment B.H. Kim, J.B. Jung, H.P. Lee and D.H. Lee			1281
Intensely irradiated steel components: Plastic and fracture properties, and a new concept of structural design criteria for assuring the structural integrity K. Suzuki, S. Jittrakorn, N. Okubo and F. Takada			1290
Seismic re-evaluation of EDF Bugey 900 PWR nuclear power plant in the frame of the 3rd periodic safety review E. Viollet, P. Labbé, E. Gallère, A. Nasrjerian, D. Vendepoute, S. Rivet, N. Humbert, C. Durouchoux, P. Pascal, M.T. Blanchard, Y. Fom, H. Jadoi, V. Louche and S. Nicolas			1306
Performance of TRISO particles fueled with plutonium and minor actinides in a PBMR-400 core design J. Bonnet, J.L. Kloosterman and B. Boer			1320
<b>Materials Engineering</b>			
Properties of DU-10 wt% Mo alloys subjected to various post-rolling heat treatments D.E. Burkes, R. Pambhokaram, T. Herrmann, J.-F. Jue and F.J. Rice			1332
Radiation-induced 'long-cell' (macro-cell) corrosion in light water reactors G. Soji			1340
Thermal frequency response studies of a hollow cylinder subject to loads of different amplitude and shape E. Pajffman, K.-T. Nilsson and N.G. Taylor			1355
<b>Material Properties</b>			
High temperature design curves for high nitrogen grades of 316LN stainless steel J. Ganesch Kumar, M. Chowdhury, V. Ganesan, R.K. Pareekar, K. Shamu Sankaran Rao and M.D. Mathew			1363
<b>Reactor Engineering</b>			
Comparison of natural convection flows under VHTTR type conditions modeled by both the conservation and incompressible forms of the Navier-Stokes equations R.C. Marín, R.A. Berry, A. Esteve, K.D. Hamman, D.A. Knoll, H. Park and W. Taitano			1371
<b>Fuel Engineering</b>			
The effect of fuel rod supporting conditions on fuel rod vibration characteristics and grid-to-rod fretting wear K.-T. Kim			1386
Online integrated visual inspection and sorting system for fast reactor fuels D. Mukherjee, K. Majeeh, C. Baglum, T. Soreng, J.P. Panikhal and H.S. Kamath			1392
The study on a statistical methodology for PWR fuel rod internal pressure evaluation K.-T. Kim			1397
<i>(Contents continued on back cover)</i>			
Available online at  <b>ScienceDirect</b> www.sciencedirect.com		Affiliated with the European Nuclear Society (ENS) and with the International Association for Structural Mechanics in Reactor Technology, e.V. (IASMIRT) 	

This article appeared in a journal published by Elsevier. The attached copy is furnished to the author for internal non-commercial research and education use, including for instruction at the authors institution and sharing with colleagues.

Other uses, including reproduction and distribution, or selling or licensing copies, or posting to personal, institutional or third party websites are prohibited.

In most cases authors are permitted to post their version of the article (e.g. in Word or Tex form) to their personal website or institutional repository. Authors requiring further information regarding Elsevier's archiving and manuscript policies are encouraged to visit:

<http://www.elsevier.com/copyright>



Contents lists available at ScienceDirect

## Nuclear Engineering and Design

journal homepage: [www.elsevier.com/locate/nucengdes](http://www.elsevier.com/locate/nucengdes)

## Molten salt reactors: A new beginning for an old idea

David LeBlanc<sup>a,b,\*</sup><sup>a</sup> Physics Department, Carleton University, 1125 Colonel By Drive, Ottawa, ON, Canada K1S 5B6<sup>b</sup> Ottawa Valley Research Associates Ltd., Canada

## ARTICLE INFO

## Article history:

Received 24 September 2009

Received in revised form 3 December 2009

Accepted 18 December 2009

## ABSTRACT

Molten salt reactors have seen a marked resurgence of interest over the past decade, highlighted by their inclusion as one of six Generation IV reactor types. The most active development period however was between the mid 1950s and early 1970s at Oak Ridge National Laboratories (ORNL) and any new re-examination of this concept must bear in mind the far different priorities then in place. High breeding ratios and short doubling times were paramount and this guided the evolution of the Molten Salt Breeder Reactor (MSBR) program. As the inherent advantages of the molten salt concept have become apparent to an increasing number of researchers worldwide it is important to not simply look to continue where ORNL left off but to return to basics in order to offer the best design using updated goals and abilities.

A major potential change to the traditional Single Fluid, MSBR design and a subject of this presentation is a return to the mode of operation that ORNL proposed for the majority of its MSR program. That being the Two Fluid design in which separate salts are used for fissile  $^{233}\text{UF}_4$  and fertile  $\text{ThF}_4$ . Oak Ridge abandoned this promising route due to what was known as the “plumbing problem”. It will be shown that a simple yet crucial modification to core geometry can solve this problem and enable the many advantages of the Two Fluid design. In addition, another very promising route laid out by ORNL was simplified Single Fluid converter reactors that could obtain far superior lifetime uranium utilization than LWR or CANDU without the need for any fuel processing beyond simple chemistry control. Updates and potential improvements to this very attractive concept will also be explored.

© 2010 Elsevier B.V. All rights reserved.

## 1. Introduction

A molten salt reactor (MSR) is one in which fluorides of fissile and/or fertile elements such as  $\text{UF}_4$ ,  $\text{PuF}_3$  and/or  $\text{ThF}_4$  are combined with carrier salts to form fluids. Single Fluid designs have both fertile and fissile combined in one salt, whereas the lesser known Two Fluid design has separate salts for fissile ( $^{233}\text{UF}_4$ ) and fertile ( $\text{ThF}_4$ ). Typical operation sees salt flowing between a critical core and an external intermediate heat exchanger. A secondary coolant salt then transfers heat to steam or closed gas cycle. The vast majority of work has involved fluoride salts as corrosion resistant alloys have been shown to be compatible with these salts. Chloride based salts have also been proposed, especially for fast breeder designs, but have unique problems and lack operational experience to draw upon. Designs specifically for the  $\text{Th}$ - $^{233}\text{U}$  cycle using fluoride salts have recently been termed Liquid Fluoride Thorium Reactors (LFTR) and is a term becoming more widely used.

The most common carrier salt proposed are mixtures of enriched (>99.99%)  $^7\text{LiF}$  and  $\text{BeF}_2$  termed “flibe”. Mixtures with upwards of 14%  $\text{ThF}_4$  and/or  $\text{UF}_4$  have melting points below a traditional limit of  $525^\circ\text{C}$  which gives adequate margin for use with the high nickel alloy Hastelloy N. This alloy is rated for use up to  $704^\circ\text{C}$  with these molten salts and options exist to employ newer, ASME Section III qualified materials such as Alloy 800H clad with Hastelloy N. It has been suggested that carbon based structures or refractory metals could be used throughout the primary loop including heat exchangers which would allow higher peak temperatures and a wider set of carrier salts with higher melting points. However, in the following presentation the more conventional temperature limits will be assumed.

Molten salt reactors have numerous operational and safety advantages over solid fuel designs. A detailed review is beyond the scope of this presentation but briefly:

- Fluid nature of the fuel means meltdown is an irrelevant term and allows the fuel salt to be automatically drained to passively cooled, critically safe dump tanks.
- Fission products either quickly form stable fluorides that will stay within the salt during any leak or accident or are volatile or insoluble and are continuously removed. Noble gases bubble out and

\* Correspondence address: Physics Department, Carleton University, 1125 Colonel By Drive, Ottawa, ON, Canada K1S 5B6. Tel.: +1 613 520 2600; fax: +1 613 746 9632.

E-mail address: [dleblanc@physics.carleton.ca](mailto:dleblanc@physics.carleton.ca).

- are stored outside the reactor loop. Noble and semi noble metals will plate out on metal surfaces and/or can be collected by replaceable high surface area metal sponges within the loop.
- The continuous removal of the noble gas Xenon means that there is no “dead time” of the reactor after shutdown or a power decrease that most solid fueled reactors must deal with due to the production of  $^{135}\text{Xe}$  from the decay of  $^{135}\text{I}$ . As well, no excess reactivity need be in place to deal with such events.
  - Most MSR designs have very strong negative temperature and void coefficients which act instantly, aiding safety and allowing automatic load following operation.
  - Only a low pressure vessel is needed as the salts run near atmospheric pressure as opposed to the thick walled vessels needed for LWR or PBMR. No water or sodium means no possible steam explosion or hydrogen production within the containment. In designs without graphite moderator, there is not even combustible material present.
  - Molten fluoride salts in general are excellent coolants, with a 25% higher volumetric heat capacity than pressurized water and nearly 5 times that of liquid sodium. This results in more compact primary loop components like pumps and heat exchangers. They also have a much lower thermal conductivity than sodium which avoids thermal shock issues.
  - Fissile concentrations are easily adjusted on a continuous basis meaning no excess reactivity and no need for burnable poisons. A single control rod for shutdown and start-up is often included but is not strictly necessary given the ability to drain fuel out of the core into critically safe storage tanks.
  - Utilization of the thorium to  $^{233}\text{U}$  cycle produces several orders of magnitude less transuranic wastes than a conventional once through cycle and significantly less than even a U-Pu fast breeder (based on 0.1% losses during fuel processing). This leads to radiotoxicity of waste being less than equivalent uranium ore levels within a few hundred years.
  - Fuel processing and utilization of thorium permits break even breeding with ease and ability to reach a breeding ratio of 1.06 or even up to 1.13. Adding  $^{238}\text{U}$  to denature the uranium content and still break even is also possible.
  - Break even operation only requires approximately 800 kg of thorium per GW(e) year added simply as  $\text{ThF}_4$ . Start-up fissile requirements can be as low as 200 kg/GW(e) or upwards of 5.5 tonnes in harder spectrum designs, with 700–1500 kg more common. Thorium start-up inventory varies from 50 to 200 tonnes per GW(e).
  - Terrestrial thorium is 3 times as abundant as uranium with large proven reserves even with the small current usage. As example, a single new deposit in Lemhi Pass Idaho has recently added 600,000 tonnes to the world's proven reserves increasing reserves by 50%.
  - Without any fuel processing, MSRs can run as simple converters with excellent uranium utilization even on a once through cycle (less than 1/3 that required for LWR).
  - MSRs offer large advantages for the destruction of transuranic wastes from traditional once through reactors. TRUs may also be used as start-up fissile inventory in most designs.

## 2. Background and history

Molten salt reactors were developed primarily at Oak Ridge National Laboratories (ORNL) beginning in the late 1940s. Almost 30 years of funded research and development followed a design evolution leading to the adoption in the late 1960s of what is known as the Single Fluid, graphite moderated MSBR (Weinberg et al., 1970). What is important to realize is that this evolution was guided by priorities and limitations that are far different than

now exist. In particular, the overwhelming priority given to the MSBR program was a minimization of the doubling time, the time to breed the start-up fissile inventory of the next reactor. The two routes for this are decreasing the necessary start-up inventory and increasing the breeding ratio. This mandated priority was due to the early belief that nuclear power would follow an exponential growth and that uranium supplies were severely limited. Associated to this was that the MSBR's main competition was the well funded liquid sodium cooled fast breeder whose potential doubling time was impressive at the time but later would be greatly lengthened due to the need to soften the neutron spectrum for safety reasons.

The development of MSRs can be categorized into four eras. The very first work was in support of the Aircraft Reactor Program for the U.S. Air Force. The concept being an onboard MSR to replace combustion heat for the jet engines of bombers. While this project did not lead to an operational bomber, it did lead to a large knowledge base being developed and to a successful test reactor, the Aircraft Reactor Experiment. The ARE was a high temperature reactor with a peak temperature of  $860^\circ\text{C}$  employing a  $\text{NaF-ZrF}_4$  carrier salt and fuelled with highly enriched  $^{235}\text{U}$ . Clad blocks of  $\text{BeO}$  provided moderation.

A true molten salt program began in the mid 1950s to investigate power station designs to be either simple converter reactors or potential break even or breeder reactors on the  $\text{Th-}^{233}\text{U}$  cycle. These took the form of very simple sphere within sphere, two region designs as depicted in Fig. 1. A central molten salt core would contain fissile and also usually fertile material and was surrounded by a  $\text{ThF}_4$  containing blanket salt. The  $^7\text{Li-BeF}_2$  carrier salt itself is capable of modestly efficient moderation of neutrons such that a wide variety of spectrums from soft epithermal to fairly hard were examined. A Hastelloy N barrier between regions was to be employed. In later years it would be found that such a usage within the core and thus within a high neutron fluence would have a limited lifetime due to helium embrittlement from  $(n,\alpha)$  reactions in nickel and boron contaminants.

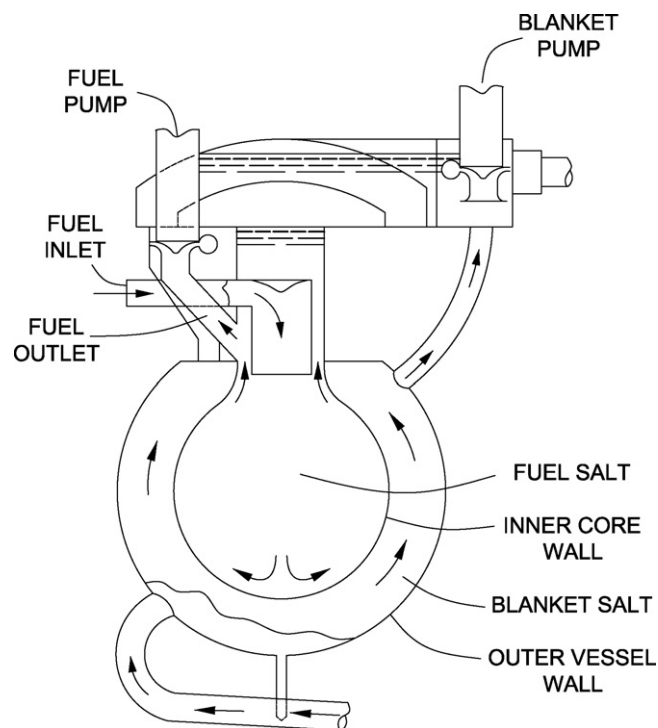

Fig. 1. Depicts Oak Ridge's two region concept of the 1950s. Reproduced from ORNL 2474.

By 1960 it was determined that graphite was indeed capable of long term interaction with the salts and appeared to offer a way of more efficient neutron moderation and the potential to lower fissile starting loads. The use of graphite within the core also gave researchers at ORNL the hope that a true Two Fluid design could be made practical.

A Two Fluid design uses a fuel salt that carries the fissile  $^{233}\text{UF}_4$  and a separate blanket salt for the fertile  $\text{ThF}_4$ . As  $^{233}\text{U}$  is produced in the blanket, it is transferred to the fuel salt by a simple fluorination process. Fluorination is accomplished by bubbling fluorine gas through the salt which converts  $\text{UF}_4$  to volatile  $\text{UF}_6$ . Gaseous  $\text{UF}_6$  is collected and converted back to  $\text{UF}_4$  by a well established process before being added to fuel salt.

The main advantage of a Two Fluid system is that processing out fission products from the fuel salt is greatly simplified by the absence of thorium. The prime method being known as vacuum distillation (Scott et al., 1966) developed in 1964. After removal of all  $\text{UF}_4$ , the carrier salt would be evaporated off and recycled, leaving most fission products behind.

Furthermore, the neutron losses to  $^{233}\text{Pa}$  can be minimized as it is effectively diluted in the much larger volume of blanket salt and experiences a lower neutron flux.  $^{233}\text{Pa}$  is the 27 day half live intermediate which decays to  $^{233}\text{U}$  following its production by a neutron absorption in  $^{232}\text{Th}$ . Thus Two Fluid designs do not require any complex and rapid processing to remove Pa to allow it to decay to  $^{233}\text{U}$  as is often thought necessary. ORNL often did propose Pa removal in much of their Two Fluid work but only to slightly improve breeding ratios (1.07 vs. 1.05). There would be little modern incentive to include Pa removal and large economic and other benefits from avoiding this process.

In this new concept, the graphite was to be used to internally separate the fuel salt and blanket salt within the core (Robertson et al., 1970) as shown in Fig. 2. However this use of graphite “plumbing” of hundreds of tubes proved a large challenge as a crack in any tube might mean replacement of the entire core and vessel due to its complexity. Under fast neutron fluence, graphite will first contract and then expand which leads to a limited lifetime depending on power density and graphite temperature. Fairly high power density cores were preferred by ORNL giving typical graphite lifetimes of 4 years before reaching a peak fluence of  $3 \times 10^{22}$  n/cm<sup>2</sup> ( $E > 50$  keV). A further complication is the contraction and expansion of graphite also led to a troublesome changing ratio of fuel to blanket salts within the core which could adversely affect reactivity. It is a testament to the advantages of Two Fluid design that ORNL stuck with this complex design until the late 1960s despite these often termed “plumbing problems”.

Also during the 1960s, the highly successful test reactor, the Molten Salt Reactor Experiment was constructed and operated. It was an 8 MW(th) design chosen to be a Single Fluid for simplicity. It operated for nearly 5 years with great success. Two unknown issues with Hastelloy N did surface, one was corrosion induced by the fission product tellurium and the other was irradiation damage caused by (n,α) reactions in nickel and boron contaminants. In subsequent years of the program, these issues were largely addressed by modifying the alloy makeup of the Hastelloy and the reduction potential of the salt accomplished simply by the occasional additions of metallic beryllium. It is likely though that Hastelloy N has a limited lifetime if used within the full neutron flux of the core. Use in the outer vessel walls and heat exchangers should pose little problem but substantial work will be required in order to qualify any new alloys for ASME Section III use.

In 1968 the development of a new fission product removal method that could function in the presence of thorium and an ingenious technique to limit neutron leakage in a Single Fluid design along with the plumbing problems of the Two Fluid design mentioned above led ORNL to abandon its Two Fluid breeder concept.

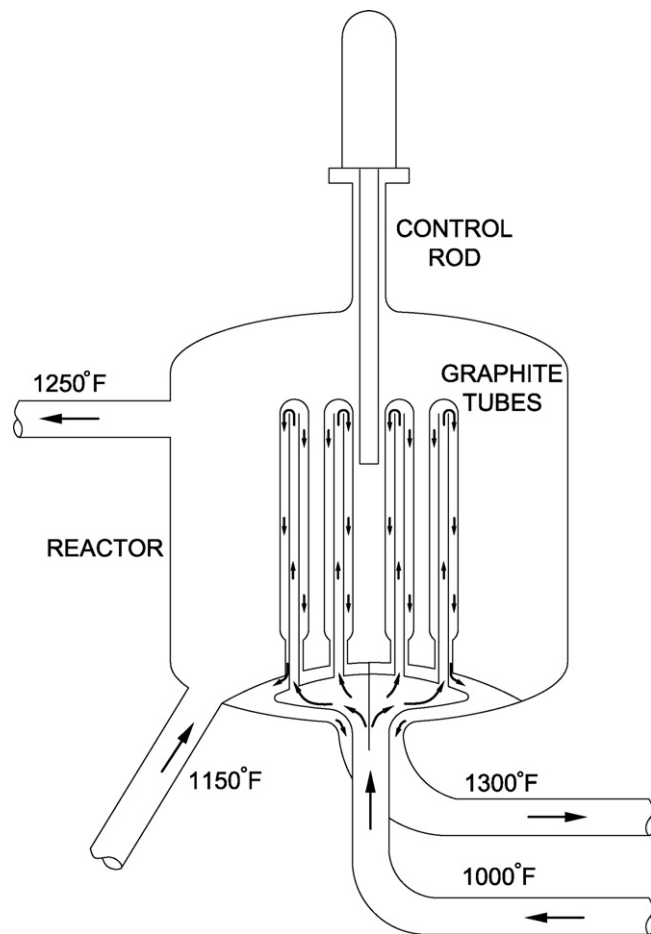
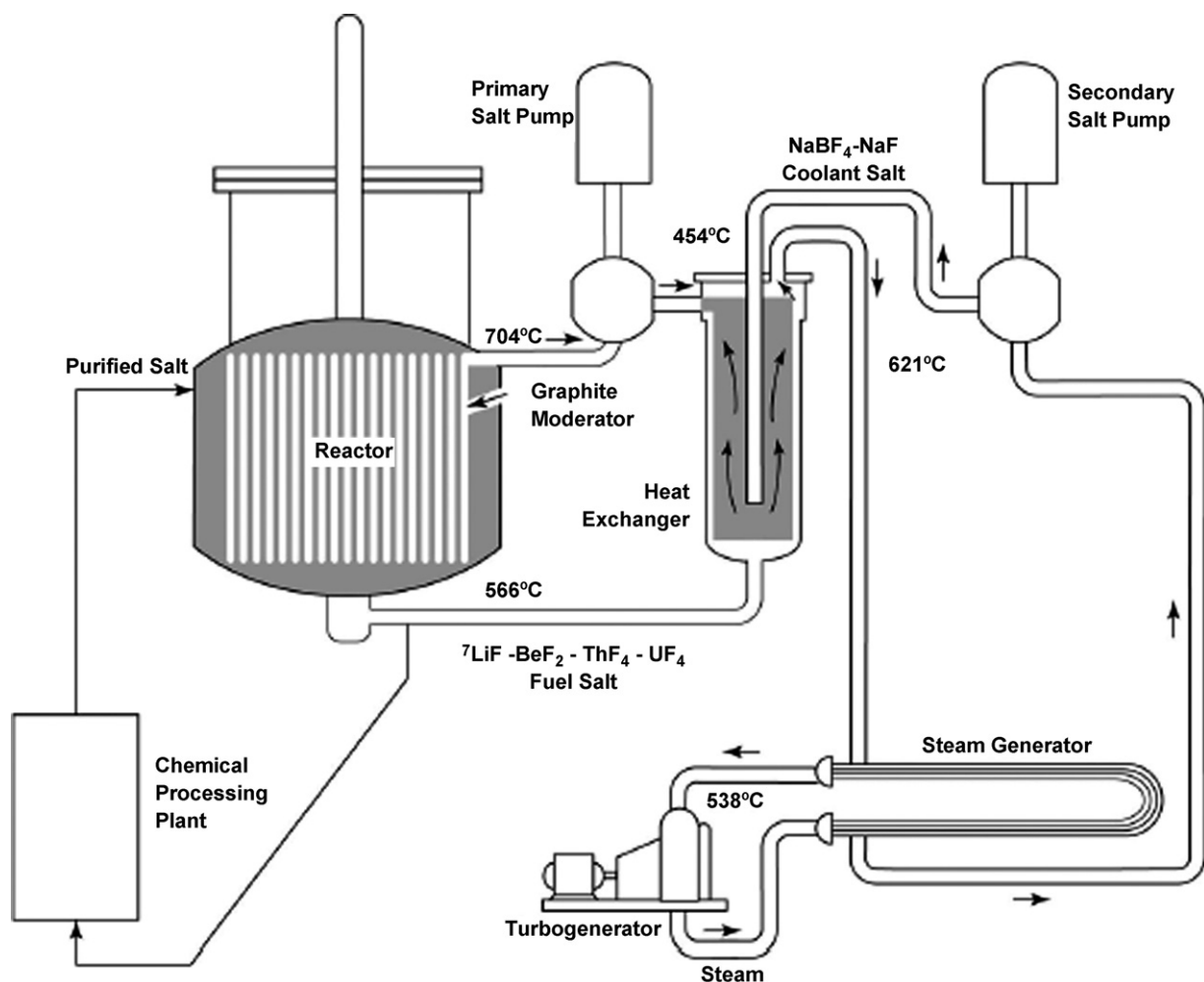

Fig. 2. Generalized depiction of the 1960s intermixed Two Fluid MSBR design using internal graphite plumbing. Reproduced from ORNL 4528.

Liquid Bismuth Reductive Extraction (McNeese, 1971), while not a simple technique, was shown to be able to differentiate between thorium and the very important rare earth fission products. Single Fluid designs with both thorium and  $^{233}\text{U}$  within the same salt also mean that  $^{233}\text{Pa}$  will be a larger drain on the neutron economy. In ORNL's MSBR design the Breeding Ratio would drop from 1.06 down to 1.01 if  $^{233}\text{Pa}$  was not removed on a 3–10 day time frame (Rosenthal et al., 1970). Given the strong emphasis placed on breeding at the time they felt Pa needed to be removed and allowed to decay outside the core before being returned as  $^{233}\text{U}$ . Pa removal is also accomplished by Liquid Bismuth Reductive Extraction. It is worth noting that while this technique for removing fission products can function with thorium present in the salt, it works far better without it as thorium is chemically similar to the rare earth fission products. Thus there is still a great advantage to Two Fluid designs when it comes to fission product removal.

Another area of advance that made a Single Fluid graphite moderated concept appear more attractive was the idea of employing an under moderated outer zone of the graphite core in which a higher ratio of fuel salt to graphite hardened the spectrum and led to the region being a net absorber of neutrons. This results in a great reduction in neutron leakage and/or reflector losses. Typically about 12% salt volume proved best in the inner zone while 37% salt volume was proposed for the outer absorbing zone. The 37% value was chosen to allow the possible use of graphite pebbles. A random bed of pebbles occupying 63% of the volume (although typically 61% is now generally assumed).

The end result was what might be termed the 4th era of molten salt development and produced the “traditional” Molten



**Fig. 3.** The 1970s Single Fluid, graphite moderated Molten Salt Breeder Reactor. Breeding Ratio of 1.06, with a specific inventory of 1500 kg/GW(e). Reproduced from ORNL 4812. Freeze plug and drainage system to dump tanks not shown.

Salt Breeder Reactor design (Weinberg et al., 1970), Fig. 3, which has been included as one of six Generation IV reactors relatively unchanged. This design has a starting fissile load of 1500 kg  $^{233}\text{U}$ /GW(e), a Breeding Ratio of 1.06, a 20 year doubling time, a 20 day cycle for fission product and 3 day cycle for  $^{233}\text{Pa}$  removal (both by Liquid Bismuth Reductive Extraction). Sealed graphite is used to limit Xenon retention with a 4 year cycle between graphite replacement. The 1000 MWe design has an average power density of 22 MWth/m<sup>3</sup> and a core size of 5 m diameter and 4.3 m height.

In the early 1970s however, for reasons many would argue far more political than technical, the MSBR program was terminated by the AEC. Corrosion issues that were already well on their way to being addressed were the main faults mentioned (Shaw, 1972) and which unfortunately have become engrained in memory. Certainly significant work is still needed to qualify materials for the primary loop including heat exchangers but the materials challenge is likely far less than the AEC report implied. The sudden termination of funding also meant the Single Fluid design became the textbook design and little mention of alternatives has appeared until very recent years. Oak Ridge did continue a modest program until the early 1980s, with a greatly increased value placed on maximizing proliferation resistance. ORNL examined operating on denatured cycles in which all uranium stayed below the weighted average of 12%  $^{233}\text{U}$  and/or 20%  $^{235}\text{U}$ . The results were surprisingly successful, with two routes examined, both termed DMSR for Denatured Molten Salt Reactor. The first a DMSR break even design (Engel

et al., 1978) with similar fission product processing to the MSBR and showed that break even breeding could be accomplished even while remaining in a denatured state using depleted  $^{238}\text{U}$  and Th as the fertile makeup. The second was a greatly simplified DMSR converter design called the “30 Year Once Through Design” (Engel et al., 1980) without any fuel processing beyond chemistry control for a full 30 years while still maintaining a very high conversion ratio and excellent uranium resource utilization. Both designs also featured larger, low power density cores that gave a full 30 year lifetime of the graphite.

Over the next 20 years however, little advance was made as funding worldwide was virtually non existent. Many vocal proponents worldwide such as Charles Forsberg and Uri Gat of ORNL and Kazuo Furukawa in Japan at the very least kept interest active during lean times for all nuclear designs (Forsberg, 2006b; Furukawa et al., 1990; Furukawa et al., 2008; Gat et al., 1992; Gat et al., 1997).

### 3. A resurgence of interest

The selection of molten salt reactors as one of the six Generation IV reactors in 2002 has certainly contributed to an increase in interest. Much recent activity has also been based on molten salt reactors acting as transuranic waste burners. There are numerous advantages in this regard as no solid fuel elements require fabrication, all minor actinides can be included and there are no concerns over varying isotopic compositions. Most initial TRU burner work looked

to modify graphite moderated designs and/or employ subcritical accelerator driven concepts (Bowman, 1998; Furukawa, 1992). The latest work (Greenspan et al., 2007; Ignatiev et al., 2007) points to graphite free systems being an optimal route. A technical issue in designs looking to only burn TRUs is that trifluoride actinides such as  $\text{PuF}_3$  are much less soluble in carrier salts compared to  $\text{UF}_4$  or  $\text{ThF}_4$ . Thus maintaining criticality on TRUs alone is a challenge. The carrier salt  $\text{NaF-LiF-BeF}_2$  has been shown to be adequate and forms the basis of the MOSART (Ignatiev et al., 2007) design out of Russia.

It should also be mentioned that burning TRUs with what is termed thorium or uranium support is also an interesting option (Lecarpentier, 2001). TRUs, especially from once through LWRs, have plenty of reactivity to start a MSR. It is only after a poorer isotopic blend of more fertile actinides has built up with time does maintaining criticality become an issue. Thus during start-up, significant amounts of thorium or uranium can be included with the TRU start charge. The in situ production of fissile  $^{233}\text{U}$  and/or  $^{239}\text{Pu}$  then helps the reactor maintain criticality long term. The presence of thorium or uranium also helps broaden the choice of carrier salts and can actually increase the solubility of  $\text{PuF}_3$ . This mode of operation does not however consume as much TRUs annually as a pure burner. Transuranics can also of course be effectively consumed by using them as the starting fissile inventory for a wide range of molten salt designs. This is likely the most attractive option.

In terms of general power reactor designs, the most intensive new efforts have been in France, centered in Grenoble where a major modeling, design and salt chemistry program is taking place. This work has included discovery of a reactivity problem with the traditional Single Fluid MSBR design. While the temperature coefficient has the needed fast acting negative term, as graphite gradually heats up, the overall temperature coefficient becomes positive, not negative as ORNL had calculated. They have proposed remedies to this but they have reached the conclusion that moving away from graphite moderation will attain the best results. Their latest design offering utilizes a 78%  $^7\text{LiF}$ -22%(Th+U) $\text{F}_4$  fuel salt as core, surrounded by a radial blanket of  $\text{LiF-ThF}_4$  and axial reflectors. Termed the Thorium Molten Salt Reactor (TMSR) (Merle-Lucotte et al., 2007a), the combination of high fissile load (5.5 tonnes  $^{233}\text{U}/\text{GW}(\text{e})$ ) and at least a partial thorium salt blanket results in a high breeding ratio of 1.13 for a 6 month fission product removal rate and the ability to extend this processing time to 20 years and still break even.

Work involving molten salts has also increased in the U.S. but in a rather different way. There is a significant effort in promoting the use of molten salts as simple coolants for high temperature solid fuel reactors based on TRISO fuel elements. These designs are termed Molten Salt Cooled Reactors (MSCR) or more recently Advanced High Temperature Reactors (AHTRs) (Forsberg, 2006a; Peterson et al., 2008). Molten salts have high heat capacity and other excellent heat transfer qualities. This lowers pumping requirements, results in smaller heat exchangers and allows high power cores to have adequate decay heat removal by natural circulation of the salt. The major design constriction this work faces is assuring a negative coolant void coefficient which has proved challenging but attainable. This work would entail much engineering development that would be directly relevant to molten salt fuelled designs.

#### 4. Changing priorities and flexibility of design

As mentioned, the priorities mandated to ORNL during early development would be quite different than those today. As well, there is likely to be disagreements at a personal up to a national level in regards to ranking of priorities and how well different designs meet those priorities. In no particular order, Net Power

Cost, Long Lived Waste Reduction, Overall Safety, Proliferation Resistance and Resource Utilization form the basis for optimization.

Overall safety is an area in which a variety of MSR designs can perform exceptionally well, due mainly to the many inherent safety features. Thus, while safety is undoubtedly of utmost importance, it is likely that various new MSR design proposals will only have a modest difference in this area. On the surface at least, there may be some advantage of softer spectrums using graphite giving longer prompt neutron lifetimes but even quite hard spectrum designs have done well in reactivity excursion studies (Merle-Lucotte, 2007b).

Long lived waste reduction is also an area that any MSR can perform admirably. The long term radiotoxicity in LWR spent fuel is dominated by transuranic elements. The much lower production rate along with the ability to return any produced TRUs to the core or simply keep them in the salt for the core lifetime can convert a "million year" problem of spent fuel into a "300 year" issue of simply allowing for the majority of fission products to decay. However, the costs involved do lead to a consideration of what level of effort is employed versus the effect on net power costs. That optimization undoubtedly falls within a national mandate but it would appear well worth any modest expense to virtually eliminate transuranics going to waste. The lack of transuranics also has the additional benefits of removing any remote concerns over accidental criticality events such as how LWR spent fuel can become critical if stored in too high a density in the presence of water. As well, it removes any proliferation concerns over waste storage or disposal sites becoming a future "plutonium mine".

Proliferation resistance is a highly contentious subject but one of great importance. It is a complex debate in comparing various MSR designs to each other and to other reactor designs and is beyond the scope of this document. At a minimum though, it must be stated that there is great flexibility to address this issue. The pure Th- $^{233}\text{U}$  cycle in MSR has many inherent proliferation resistant features including the presence of  $^{232}\text{U}$  whose decay chain has a strong 2.6 MeV gamma emitter along with the ability to instantly denature a molten salt on demand (Sorensen, 2007) by the addition of  $^{238}\text{UF}_4$ . It does however represent the use of Highly Enriched Uranium which some might immediately find unacceptable. However, MSRs can also run denatured by the addition of  $^{238}\text{U}$  into the process and still break even on breeding (Engel et al., 1978). Alternatively, simple DMSR converter reactor designs (Engel et al., 1980) burning LEU with thorium offer perhaps the highest and most transparent level of resistance as no fuel processing equipment is part of the plant, all uranium remains denatured and any plutonium in the fuel salt is very difficult to remove and is of extremely poor quality for weapons use due to high  $^{238}\text{Pu}$  and  $^{242}\text{Pu}$  content.

Resource utilization is an area that all MSR designs do well but can still vary greatly so it is important to quantify this priority precisely. The first issue is the quantity and quality of fissile material needed for start-up which can affect how rapidly reactors are deployed. How much fissile is required? Can spent fuel TRUs be used? Can LEU be used? Spent fuel transuranics, while abundant, could still limit deployment and are costly to extract from solid spent fuel. Second is the quantity of resources needed after start-up. Obviously a break even design minimizes this need as only about 600 to 800 kg/GW(e) year of fertile Th and/or depleted U are needed annually. A converter or burner design may require a larger annual resource of uranium ore, but these designs may prove better able to optimize all other priorities. The attractiveness of converter designs will undoubtedly rest upon the debate surrounding "Peak Uranium" as well as the public acceptance of uranium mining. This question may also depend upon a nation's inherent resource or having a secured foreign supply.

Net power cost is an area that also appears to offer great advantages over other reactor types. Between MSR designs most reactor

components will have a great deal of similarity. Cost and complexity of the core itself along with the costs and R&D needs of any on site or centralized fuel processing are likely the major differentiators.

It is highly likely that different MSR designs may prove optimal for different nations, vendors or utilities. Thus it is likely a best option to thoroughly investigate more than one design. The following represents major new areas being proposed and investigated by the author.

### 5. Solving the two fluid plumbing problem

All original fluid fuel reactor designs involved utilizing two zones, a central core or seed zone surrounded by a fertile blanket (i.e. thorium). For the  $^{233}\text{U}$ -Th cycle, the core might contain a mix of  $^{233}\text{U}$  and Thorium or in some cases only  $^{233}\text{U}$ . ORNL differentiated between these two cases by the terms “Two Fluid” for only fissile  $^{233}\text{U}$  in the core and “1 and 1/2 Fluid” designs if the core salt contained thorium as well.

Early in development, the advantages of a Two Fluid design became evident. If the core salt lacked thorium, it would be far easier to process out fission products. However a core with only fissile salt will have a quite small critical diameter if the fissile concentration is also kept high enough to limit neutron losses to the carrier salt and/or graphite. This critical diameter is on the order of 1 m for either pure salt or heterogeneous cores employing graphite. Since power density has limitations for many reasons, such a small core would have very limited power output. ORNL's solution was to use plumbing to intermix the Two Fluids within the core zone. However, as previously reviewed, this proved unmanageable.

A new solution proposed by the author may in fact be surprisingly simple (LeBlanc, 2008). Traditionally reactor cores are spherical or short cylinder primarily to minimize neutron leakage. If a Two Fluid design has an encompassing blanket, leakage is not an issue. The simple solution thus proposed is a core geometry switch to increase the power producing volume while maintaining the required small critical diameter.

As a first approximation the critical diameter will be the ratio of the Buckling constants between the given geometries. Thus, for the same fuel salt and/or graphite combination, a long cylinder will have a critical diameter approximately 77% that of a sphere. If a specific combination of fissile concentration, graphite and carrier salt gives a critical diameter of 1 m for a sphere, then a long cylinder would have critical diameter of 0.77 m.

The great advantage of going to an elongated cylinder or slab is the fact that a practical total power can now be obtained without intermixing but by simply extending the length of the core. A single barrier needs to be maintained between the core and blanket regions, which is far less complex than the internal plumbing of fuel and blanket salts in ORNL's Two Fluid designs. In terms of end plenums on these cylindrical cores, a possible arrangement would be to taper the ends to a sub critical diameter while still surrounded by the blanket salt, see Fig. 4. This will all but eliminate

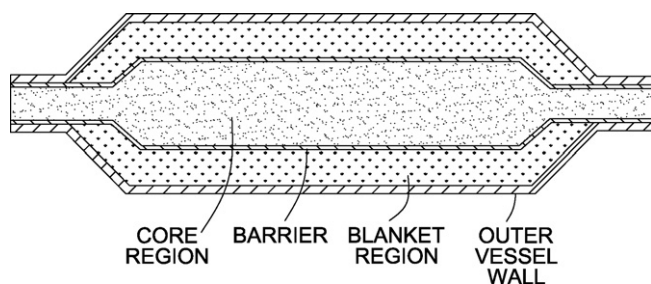

Fig. 4. Generalized depiction of an elongated cylindrical Two Fluid core with encompassing blanket salt. Inlet/outlet for blanket salt cooling are not shown.

leakage of neutrons. While modeling efforts are ongoing, previous calculations from ORNL work of homogeneous designs of the late 1950s and Two Fluid graphite work of the 1960s can be used to a significant degree to predict characteristics.

Such a design will have a strong negative temperature and void coefficient for the fuel salt which is true for any Two Fluid design. A major improvement over ORNLs internally separated Two Fluid design is that the blanket should also have negative coefficients. This is due to the fact that the outer blanket acts as a weak neutron reflector. Thus lowering its density decreases this reflective quality and lowers reactivity in the core. It should be mentioned that to attain this desired negative temp/void blanket salt coefficient, no graphite or other reflective materials should be used in the blanket zone. This is easily accomplished.

As with any fluid fuelled, two zone design, the leakage of core fluid into the blanket must be guarded against. The simplest method, proposed for all ORNL Two Fluid designs is to run the blanket fluid at a slightly higher pressure. As the blanket salt is far denser than the core salt, hydrostatic pressure alone accomplishes this. Thus any leak through the barrier will add fertile to the core and lowers reactivity.

There are advantages to employing graphite moderation including very low fissile specific inventories and providing a built in structure to aid in the barrier between core and blanket. However, the much lower overall power density of graphite designs results in the need for greater overall core volume to attain power plant levels. This likely means multiple units per plant but this also brings other operation advantages. The limited lifetime of graphite due to fast neutron damage would also entail periodic replacement as is true of most MSBR designs. The small dimension and multiple units should assist in this operation.

The total volume of salt and the fissile molar concentration dictate the specific inventory. For a graphite moderated design it should be possible to reach 0.15%  $^{233}\text{UF}_4$  molar concentration or even 0.1% or lower and still break even (i.e. breed just enough  $^{233}\text{U}$  to match consumption). Taking into account salt volume needed out of core leads to a conservative estimate of 20 m<sup>3</sup> per GW(e) as adopted in recent French studies and early ORNL work with a lower limit of perhaps 10 m<sup>3</sup> given the possible use of new compact heat exchangers to greatly reduce out of core volumes. These estimates give a potential lower limit of start up fissile inventory of a mere 150 kg/GW(e) with 400 kg/GW(e) being a more conservative goal. For comparison ORNL Two Fluid work was about 700 kg/GW(e), ORNL Single Fluid 1500 kg/GW(e), an LWR is 3–5 tonnes/GW(e) and liquid metal cooled fast breeders 10–20 tonnes/GW(e).

More impressive perhaps are the possibilities with homogenous designs lacking graphite moderator. With the entire volume of the core now being power producing salt, the needed volume is far less. Single cores for 1000 MW(e) are readily attainable although there are still advantages to smaller unit sizes. Without graphite moderation, the assumption is often made that this means a much higher specific inventory and a quite hard spectrum. However, the carrier salt itself is a fairly effective moderator and a wide variety of fissile concentration and neutron spectrums are in fact attainable. Recent French work requires a high specific inventory of 5.5 tonnes/GW(e) partly due to only having a radial blanket in the TMSR design. Attempting a much lower concentration would see a significant increase in neutron losses to the top and bottom reflectors due to the longer migration paths of neutrons before absorption. With a fully encompassing blanket, this is not an issue.

ORNL calculations (Alexander et al., 1959) from the spherical cores of the 1950s design provide an excellent tool for estimation, see Table 1. While the accuracy of such early data must of course remain suspect, it is hoped adequate for at least cursory investigations. This study assumed a 8.5 mm (1/3 in.) thick Hastelloy N barrier for cores up to 3.7 m (12 feet) diameter, thus for

**Table 1**  
Initial state nuclear characteristics of spherical two region, homogeneous, molten fluoride salt reactor with <sup>233</sup>U from ORNL 2751 (1959). Values in italics are projected by the author.

Inner core diameter	91 cm	122 cm	122 cm	183 cm	244 cm
Thorium in fuel salt	0%	0%	0.25%	0%	7%
<sup>233</sup> UF <sub>4</sub> in fuel salt	0.592%	0.158%	0.233%	0.048%	0.603%
Neutrons per absorption in <sup>233</sup> U, Be, Li and F in Fuel Salt	0.0639	0.1051	0.0860	0.318	0.078
Hastelloy N Core Wall (8.5 mm)	0.0902	0.1401	0.1093	0.1983	0.025
Li and F in Blanket salt	0.0233	0.0234	0.0203	0.0215	0.009
Leakage	0.0477	0.0310	0.0306	0.016	0.009
Neutron yield	2.1973	2.1853	2.1750	2.2124	2.200
Median fission energy	174 ev	14.2 ev	19.1 ev	0.33 ev	243 ev
Initial breeding ratio	0.9722	0.8856	0.9288	0.6586	1.078
<i>Projected B.R. thinner wall<sup>a</sup></i>	<i>1.060</i>	<i>0.9836</i>	<i>1.011</i>	<i>0.7722</i>	<i>1.099</i>
<i>Projected B.R. carbon wall<sup>b</sup></i>	<i>1.105</i>	<i>1.054</i>	<i>1.066</i>	<i>0.8714</i>	<i>1.112</i>

<sup>a</sup> Projected assuming a thinner Hastelloy core wall of 1/6 inch (4.2 mm) and 90% leakage reduction by using a thicker blanket.

<sup>b</sup> Projected assuming a graphite or carbon-carbon core wall and 90% leakage reduction by using a thicker blanket salt.

much smaller cylinders a thinner wall should suffice. The study also assumed a 60 cm (2 foot) blanket which allowed significant neutron leakage in some cases, expanding this to 100 cm should convert a high percentage of those losses into thorium absorptions.

The values of Table 1 give the initial breeding ratios, thus no losses to fission products or protactinium. ORNL also projected (MacPherson et al., 1958) long term breeding ratios for the 8 foot core case in detail. Even with a relatively long 1 year processing time for fission product removal and no protactinium separation, the breeding ratio only dropped from 1.078 to 1.044.

Taking the 3 foot (91 cm) case as example, this would equate to a 70 cm wide cylindrical core. A modest average power density of 200 MW/m<sup>3</sup> still gives impressive results. Using the standard ORNL 140 K inlet/outlet temperature change and a salt speed in core of 2 m/s gives a 505 MW(th) output from a 6.6 m long, 0.7 m wide core. At 44.4% for a steam cycle, this is 224 MW(e) with a somewhat higher output if a gas cycle is used. Including a meter thick blanket and outer vessel wall still results in a simple to manufacture design that can fit within a tractor trailer for transport.

It must be noted that Hastelloy N at the time of these early studies was thought to be good for 10 to 20 years in core. Neutron induced helium embrittlement discovered in the MSRE means that Hastelloy N might not have a long lifetime in the full flux of the core. ORNL had success in limiting this damage by modifying the alloy makeup and this trend has been continued in recent French work on the TMSR where they are now proposing a new Hastelloy alloy for both their radial blanket zone and axial reflectors (Merle-Lucotte, 2008a; Cury, 2007). Potentially a much superior metal barrier is a high molybdenum alloy which is known to have a much greater tolerance to neutron damage (Zinkle and Ghoniem, 2000). It has been suggested for use not only in molten salt fission designs but also for the barrier between plasma and a LiF-BeF<sub>2</sub> coolant salt in fusion studies. Furthermore, less expensive iron alloys including the common stainless steels 304 and 316 have also shown promise both for corrosion and withstanding neutron irradiation if peak temperatures are lowered somewhat (Zinkle and Ghoniem, 2000; Koger, 1972; Keiser et al., 1977; DiStefano et al., 1995), perhaps to 550 or 600 °C. Given the simplicity of the core wall and outer vessel combination it is also not unreasonable to assume that periodic replacement even as short as annually could be still practical and economic. Fig. 5 shows an embodiment to potentially ease periodic replacement.

Carbon based material or a simple graphite tube might also prove a workable barrier. The limited lifetime of graphite is well documented and would likely require periodic replacement. Silicon impregnated carbon-carbon composite is a leading candidate in fusion studies with molten salt coolants but questions remain regarding compatibility with the salts. There are thus many choices for a barrier material but it should be emphasized that this issue is

of central importance to this proposed design as well as any other MSR design looking to include a thorium salt blanket region.

This basic design premise has of course numerous other possible embodiments. A major area is adding either thorium or <sup>238</sup>U to the fuel salt, both of which would increase the critical diameter and lower flux levels at the barrier (i.e. shorter, wider cores). Adding thorium would appear to go against the fuel processing advantages of a Two Fluid design but given the low cost and abundance of thorium it may be optimal to simply let modest amounts be processed out with the fission products. Adding <sup>238</sup>U to both core salt and

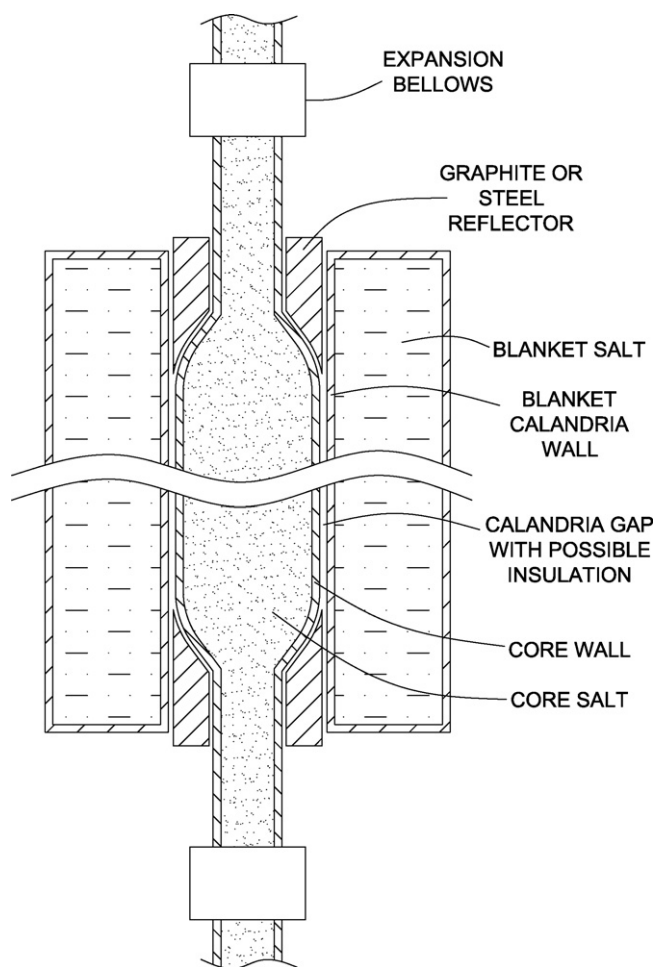

**Fig. 5.** An embodiment of a “Tube within Shell” core design employing a calandria arrangement to accommodate thermal expansion and/or tube replacement.

blanket is of course a way to operate in a fully denatured state. For the Two Fluid designs proposed, each time the blanket salt is fluorinated to remove the produced  $^{233}\text{U}$ , an appropriate amount of  $^{238}\text{UF}_4$  is added back to the thorium blanket. The amount added is enough to assure that all removals of  $\text{UF}_4$  from the blanket will have the uranium in a denatured state.

## 6. Start-up on low enriched uranium

If a truly large scale deployment of molten salt reactors is to take place, start-up fissile material may become an issue. While the starting loads are typically far less than liquid metal cooled fast breeders or even LWRs, no significant quantities of  $^{233}\text{U}$  now exist. While spent fuel transuranics are an obvious fissile source, even these may be limited and they also pose a possible proliferation and public acceptance issue of shipping TRUs to start up reactors. Highly enriched  $^{235}\text{U}$  would function and early work at ORNL typically assumed its use. However large scale production and shipments of such HEU would be ruled out today. Start-up of denatured converter designs or denatured break even designs obviously poses no problem in using LEU (<20%  $^{235}\text{U}$ ) but any attempt to start the pure Th- $^{233}\text{U}$  cycle using LEU has the issue that it may take decades or even centuries to burn off the  $^{238}\text{U}$  added with the original start-up load. LEU otherwise represents an ideal start-up fuel since it poses almost no proliferation risk in transfer to the plant and there is adequate supplies for a rapid, large scale deployment.

It can be shown however, that start-up and transition to the pure Th- $^{233}\text{U}$  cycle in Two Fluid designs is surprisingly simple (LeBlanc, 2008) as long as the specific fissile inventory needed is reasonably low, ideally less than 1000 kg/GW(e).

Step 1, purchase enough LEU to start the reactor. This will likely involve less than 2000 kg  $^{235}\text{U}$  (thus under 10 tonnes of LEU at 20% enrichment).

Step 2, run the reactor with a surrounding  $\text{ThF}_4$  containing blanket salt, but without any transfer of the produced  $^{233}\text{U}$ . Fuel processing of the fuel salt to remove fission products beyond gasses and noble metals is optional.

Step 3, as the  $^{235}\text{U}$  and some produced Pu fissions off and/or fission products build up, purchase more LEU and add to the fuel salt as needed to maintain criticality. This process will cause approximately 600–700 kg of  $^{235}\text{U}$  per GW(e) year to be fissioned off (along with perhaps 100–200 kg of core bred Pu). While this is happening, approximately 300–400 kg of  $^{233}\text{U}$  will be generated in the blanket (which can be left in the salt or fluorinated out and stored temporarily). This rough estimate of  $^{233}\text{U}$  production is based on an excess of about 0.8 neutrons per fissile absorption and an assumption of half of these being absorbed by thorium in the blanket with the rest lost to  $^{238}\text{U}$  and other actinides, salt elements, barrier and leakage.

Step 4, after perhaps a few years of operation, shut down and remove the remaining LEU from the fuel salt by simply fluorination. This can be sold to other users such as LWRs or other start-up MSR. Finally with the produced  $^{233}\text{U}$  from the blanket, the reactor can be restarted with clean carrier salt and continue running indefinitely on the Th- $^{233}\text{U}$  cycle. If the Two Fluid reactor only needs 300 or 400 kg of  $^{233}\text{U}$  then this LEU period can be as short as 1 year. Ideally one would also separate out all the transuranics from the original LEU fuel salt and burn those off in the subsequent Th- $^{233}\text{U}$  reactor.

## 7. Converter design possibilities

### 7.1. The Oak Ridge DMSR converter

While fission product processing is not overly challenging, for Two Fluid designs at least, it does mean a significant cost both in equipment and from R&D needed to verify processes on a commercial scale. Any fuel processing on site or centrally must also be examined to assure a high level of proliferation resistance. Mainly with these thoughts in mind, ORNL performed a valuable study of operating a graphite moderated, Single Fluid design as a simple converter reactor without any fuel processing for an entire 30 year plant lifetime (Engel et al., 1980). Like any MSR, gaseous fission products and noble metals would be collected and removed in a basically passive manner but fission products forming stable fluorides would simply remain in the fuel salt for the life of the plant.

The DMSR converter or “30 Year Once Through Design” entailed a larger, low power density core such that the graphite would have a full 30 year lifetime. Start-up for the 1000 MW(e) design was with 3450 kg of  $^{235}\text{U}$  added as 20% LEU. Along with this LEU was 110 tonnes of thorium to greatly improve the neutron economy in the long term. The results of this study were most impressive. The cycle always remains in a denatured state and the conversion ratio averaged 0.8 over the 30 year design. Lifetime uranium ore utilization (30 year, 75% capacity factor) was only 1810 tonnes compared to 6400 tonnes for a Once Through LWR (see Table 2). Furthermore, if a one time only simple fluorination to remove and reuse the remaining LEU is performed at the end of 30 years, then lifetime ore needs drop to about 1000 tonnes.

The resource advantage over other converter designs may seem surprising given that a conversion ratio of 0.8 does not appear that much superior to LWR and PBMR (both 0.5 to 0.6) or CANDUs (0.7). However conversion ratios do not take into account the limited residency time of fuel in solid fueled reactors. Perhaps a new term of “effective” conversion ratio would be to compare fissile consumption versus needed annual fissile additions. By this metric, most other reactors on a Once Through cycle have effective conversion ratio of near zero since they consume about 1000 kg/GW(e) year but need to add 1000 kg of fissile  $^{235}\text{U}$  per year. Even with Pu recy-

**Table 2**  
Resource utilization comparison for LWR, CANDU and molten salt 1000 MW(e) converter designs.<sup>a</sup>

	Conversion ratio	Lifetime uranium ore (tonnes)	Annual ore (tonnes)	Annual ore costs (at 100\$/kg U) 10 <sup>6</sup> \$	Annual ore costs <sup>b</sup> (1000\$/kg U) 10 <sup>6</sup> \$	Annual ore costs <sup>b</sup> (5000\$/kg U) 10 <sup>6</sup> \$
LWR Once Through	0.5–0.6	6400	200	17	170	850
LWR (Pu recycle)		4080	125	10.6	106	530
CANDU Once Through	0.7–0.75	4910	150	12.7	127	635
CANDU (Pu recycle)		2420	85	7.2	72	360
DMSR “30 Year Once Through”	0.8	1810	35.2	3	30	150 (0.02\$/kWh)
“30 Year” with one U recycle after 30 years	0.8	1000	35.2	3	30	150
“30 year” with 2 times neutron losses to salt <sup>c</sup>	0.77	1980	41	3.5	35	175
“30 year” with 5 times neutron losses to salt	0.67	2500	58	5	50	250

<sup>a</sup> Based on 30 Year Lifetime, 75% capacity factor and 0.2% uranium tails. LWR and CANDU data from “A Guidebook to Nuclear Reactors” A. Nero 1979 (U of Cal Press).

<sup>b</sup> At \$1000 to \$5000/kg, uranium recovery from sea water is likely feasible, giving an inexhaustible resource.

<sup>c</sup> Estimate value only. Based upon extra 1.53% loss of neutrons and an average of 2.1 neutrons per fissile absorption, i.e. C.R. = 0.8–2.1(0.0153) = 0.768 which equates to a shortfall of 23.2% of fissile consumption instead of 20%. Fissile consumption is approximately 800 kg/GW(e) year.

cle, they do not improve dramatically. Thus the great advantage of molten salt converter reactors is that all plutonium produced stays within the core for the full lifetime where it is mostly consumed.

In terms of long term radiotoxicity of wastes, these converter designs also perform remarkably well. All transuranics remain in the salt during operation and will not reach high concentrations due to the very large cross sections for fission and/or absorption. At the end of 30 years there is only about 1000 kg present. It is presumed prudent to perform a one time only process to remove these transuranics for recycle into the next core salt. If this is done and a typical processing loss of 0.1% is assumed, this represents a mere 1 kg of TRUs going to waste over 30 years which is about a 10,000 fold improvement over LWR once through. An average then of about 30 g per GW(e)-year of TRU waste is even better than most pure Th-<sup>233</sup>U MSR concepts that process smaller amounts of TRUs but do so much more frequently. It should be mentioned that removing and reusing TRUs does not involve isolating plutonium. The likely process would be Liquid Bismuth Reductive Extraction and Pu would remain with Am, Cm, Cf and the fission product zirconium.

Such a recycling of TRUs also has a positive impact upon lifetime uranium utilization. In ORNL's studies, at the end of the 30 year cycle, there would be 736 kg of Pu of which 331 kg would be fissile <sup>239</sup>Pu and <sup>241</sup>Pu. Along with this would be 136 kg of <sup>237</sup>Np and small amounts of Am and Cm (quantities not reported). There would also be enough uranium left to start the next cycle with clean salt, leaving the TRUs as source of fissile top up. This should save approximately 5–10% on the lifetime uranium utilization. Thus the DMSR without any recycling is about 1800 tonnes ore lifetime, with U only recycling is 1000 tonnes and with U + TRU recycling down to perhaps 900–950 tonnes ore.

Another aspect of this design which is perhaps little known is that operation as a converter with <sup>238</sup>U present leads to much improved reactivity coefficients. As mentioned, recent French work (Nuttin, 2002) brought to light that the overall global temperature reactivity coefficient of the ORNL MSBR design was actually a slightly positive +0.6 pcm/K as opposed to the small negative value of -2.4 pcm/K that ORNL calculated (pcm = 10<sup>-5</sup> Δk/k). This appears to have been due to early calculations not properly taking heterogeneous effects into account. For the converter design though, ORNL calculated (Engel et al., 1980) a much higher value of -7.2 pcm/K such that it should remain strongly negative even with up to date corrections.

Starting with ORNL's already attractive DMSR converter reactor design, what are some possible improvements? Before a review of proposed modifications a few last points should be mentioned.

All Single Fluid designs that do not attempt to remove <sup>233</sup>Pa will experience some neutron losses to Pa absorptions. Removing the need to break even on breeding means this is not of great concern but there are still two routes to lower these losses with the goal of improving uranium utilization. The first being a larger specific fissile inventory to out compete for neutrons. The larger cores and salt volumes of ORNL's converter design already accomplish this (i.e. 3450 kg fissile versus 1500 kg fissile for the MSBR). However the neutron spectrum also has a major effect. Lowest losses are seen with either a well thermalized spectrum or alternatively with a much harder spectrum. ORNL's DMSR converter design employed a softer spectrum than the MSBR for this reason.

The other extreme to lower Pa losses is attempting to keep the spectrum quite fast. There are other benefits to a faster spectrum including an improved capture to fission ratio for <sup>239</sup>Pu and fast fission bonus from <sup>238</sup>U. It should be noted though that due to very strong inelastic scattering cross sections for fluorine, such benefits are limited as these interactions quickly bring neutrons well below the MeV range. For example, even the TMSR design of

France with a very high fissile concentration and no graphite sees a <sup>239</sup>Pu capture/fission ratio of 0.53 (Merle-Lucotte, 2008b) which is only modestly better than that of well thermalized designs such as the MSBR and much higher than the value of 0.25 which can be obtained with similar fissile concentrations to the TMSR but with chloride based carrier salts. This latter value is taken from the work on the REBUS 3700 chloride salt design (Mourogov and Bokov, 2005).

Costs of the carrier salts are also an issue since typically these converter designs will employ more. For 1 GW(e), the DMSR requires 100 m<sup>3</sup>, the MSBR 54 m<sup>3</sup> and the TMSR 20 m<sup>3</sup>. The standard carrier salt flibe requires enriched lithium which unfortunately is hard to judge costs and production potential for large amounts. 100 m<sup>3</sup> of flibe will contain about 30 tonnes of 99.995% <sup>7</sup>Li with previous cost estimates being from 120 to 800 \$/kg. Even several thousand dollars per kg would still not prohibit its use but it is certainly an important issue. Beryllium metal is also an expensive item but it is a fortunate coincidence that an intermediate stage of all beryllium metal production is BeF<sub>2</sub> which means this form will have a much lower cost and have ease of large scale production.

The total volume of carrier salt is also of importance in dealing with loss of cooling or transient power events. A large volume gives the benefit of a massive heat sink, especially in combination with the heat sink of the even more voluminous graphite. While freeze plugs and automatic draining to tanks designed to deal with decay heat provide the main line of defense, it is reassuring that decay heat would take hours to bring the system anywhere near the boiling point of the salt even if zero heat removal is assumed.

## 7.2. Simple changes to the DMSR converter

Oak Ridges work on the DMSR converter was not subject to a great level of optimization of fundamental parameters. The simplest possible change would be to vary the fissile plus fertile concentration in the salt. The DMSR converter had 9.5% molar concentration of (U+Th)<sub>4</sub> in the flibe salt. This concentration can easily be lowered or raised to upwards of 14–18% without raising the melting point beyond traditional limits for Hastelloy N use. Lowering the concentration would mean a smaller starting fissile load, important for initial costs but this would lower the long term conversion ratio and mean a higher lifetime uranium requirement. Going to a higher fissile specific inventory, say to the same 5 tonnes <sup>235</sup>U per GW(e) LWRs currently require would mean much improved annual and lifetime uranium requirements. Considering the ease of which uranium content is recycled out of the salt at the end of a batch cycle, this option is especially attractive.

Changing the <sup>235</sup>U concentration in the LEU is also a possible desire. The use of LEU with 20% <sup>235</sup>U attains the best uranium utilization but this may entail difficult licensing issues for production on a large scale. A level of 10–15% might be a compromise that would only slightly increase the required annual uranium. Operation on LEU alone is also possible and would require about 4.6% LEU if the same starting fissile load of 3450 kg <sup>235</sup>U is assumed. Makeup fuel could be 5–6% LEU to still fall within current licensing. Operation on LEU alone would require a shorter batch time of perhaps 15 years or lower to limit the build-up of <sup>238</sup>U and would likely average a conversion ratio of about 0.7 instead of 0.8 and require at least 1500 tonnes ore over two 15 year cycles as opposed to 1000 tonnes for the standard 30 year DMSR with uranium recycle and 6400 tonnes for a PWR once through. Such operation on LEU alone or with only very small amounts of thorium brings about other potential advantages which will be examined in more detail in Section 7.6.

Another route for simple change is to lower the 30 year batch time that the salt is used (22.5 years full power equivalent). As long as uranium and hopefully transuranics are recycled into another batch of salt, this greatly lowers the already impressive lifetime uranium requirement. This would also lower the peak inventory of fission products within the salt, one drawback to the DMSR converter design. It should be mentioned that it is typically the fission products with hours or days long half lives which are of most concern in any accident scenario. These will be in similar concentrations for designs that remove fission products every few weeks, every few years or even every few decades.

Another advantage of lowering the batch cycle time is an improvement of quality of the uranium to be recycled. If a batch time of 15 years is used, the recycled uranium is still very reactive (8.3%  $^{233}\text{U}$  and 4.3%  $^{235}\text{U}$ ) (Engel et al., 1980). It is also more than needed to restart with clean carrier salt with a remainder being available for several years worth of top up uranium additions. In ORNL's work with a 30 year cycle time, it was felt that re-enrichment of the recycled uranium would be necessary because by the 30 year mark, the  $^{233}\text{U} + ^{235}\text{U}$  fraction would be a bit low (5.7% and 3.7% respectively). Two 15 year batch cycles with uranium recycle would likely drop the 30 year uranium utilization down to 700 tonnes ore (600 tonnes U) or perhaps 625 t ore with both uranium and transuranic recycle (1/10th that of LWR once through).

With shorter batch cycle times, it is more likely that the carrier salt itself would be recycled at a central facility by removing the soluble fission products for long term storage. The option also exists to separate out the few long lived fission products such as  $^{99}\text{Tc}$  for transmutation at the penalty of a slight increase in uranium needs. Some of these, including  $^{99}\text{Tc}$ , do not form stable fluorides so they cannot be simply placed back into the salt but they could be embedded into future core graphite elements for transmutation. Thorium can also be recycled from the carrier salt but there is not a strong economic incentive given its low cost and abundance. If it is not recovered, then about 100 tonnes thorium per batch cycle is needed (only about 3 million dollars worth).

Even with ORNL's 30 year design it is likely that a plant refurbishment would be desired to extend plant life beyond 30 years. This would entail replacing the graphite and perhaps the outer vessel. Of course, lowering power density to give 60 or more years of graphite lifetime is possible but going to smaller cores, higher power densities and shorter graphite lifetimes might also be attractive to reduce initial capital costs. Removing the need to replace graphite was always one of the great simplifications of the DMSR designs but one that is not tied to the many other proliferation and cost saving advantages of the DMSR converter.

Higher power density will typically mean a lower salt volume, thus lower fissile inventory and result in more neutron losses to  $^{233}\text{Pa}$ . However in the DMSR design these losses only amounted to 0.36% of neutron absorptions (0.18% to  $^{233}\text{Pa}$  which is doubled to account for the neutron that created it from  $^{232}\text{Th}$ ). For example, with a smaller core and a total volume of salt of 25 m<sup>3</sup> instead of 100 m<sup>3</sup>, losses to  $^{233}\text{Pa}$  would increase to 1.44% but this would only drop the average conversion ratio by about 0.023 (from 0.8) and only increase lifetime uranium needs by about 100 tonnes ore. Leakage of neutrons would be increased slightly in a smaller core but there would also be a benefit of better  $^{241}\text{Pu}$  utilization since in the DMSR study 4% of it decays before it is consumed. In terms of losses to fission products, by also using 1/4 length batch cycle of 7.5 years, the time averaged fission product concentration and associated neutron losses would be approximately the same.

Such an operation of 1/4 volume, 1/4 batch time would also mean just over 1/4 the fissile start-up inventory (somewhat more is needed to have a higher  $k_{\text{inf}}$  for a smaller diameter core). Thus about 900 kg  $^{235}\text{U}$  in LEU per GW(e) if other core parameters remained

the same. This would significantly lower capital costs and make rapid deployment all the simpler (PWRs require about 5000 kg per GW(e)). While graphite replacement is not unduly complicated, in subsequent sections an alternate method of easing graphite replacement will be reviewed.

A final simple change to mention would be to switch from batch replacements of the salt to small but continuous salt replacements. If the fuel salt is replaced in small amounts equivalent to replacing the entire volume over 30 years this would save on neutron losses to fission products by about a 1.5 ratio based on ORNL estimates. Thus a 30 year continuous cycle is equivalent to a 20 year batch cycle and lowers the needed uranium ore. This would only represent about 9 L of salt per day.

### 7.3. Simple tank of salt DMSR converter

One might consider attempting to remove graphite altogether, simply running a large tank of salt as the core. The carrier salt itself is a fair moderator of neutrons so a wide choice of neutron spectrum is still possible. There are several issues though, that decrease the attractiveness of this simple core design. One is that  $^{238}\text{U}$  resonance absorptions will be of greater relevance, thus if using LEU as starting fuel, it will be difficult to add very much thorium and still maintain criticality. This means less contribution from the neutron rich Th- $^{233}\text{U}$  chain and greater uranium ore needs. As well, it is unavoidable that neutron losses to the carrier salt will be larger than the combined salt + graphite losses of the traditional design. Studies on early sphere within sphere graphite free designs (Alexander et al., 1959) of the late 1950s fueled on 93%  $^{235}\text{U}$  and thorium can give an indication of potential results. A long term average conversion ratio of greater than 0.5 is unlikely with LEU + Th unless high fissile concentrations and thus high specific inventories are employed. High fissile starting loads could significantly affect start-up costs and ability for rapid deployment.

A simple tank of salt also has no ability to have an undermoderated outer blanket zone to help limit neutron leakage like a graphite design can do. In fact, it is likely that any simple salt tank design would require graphite liner/reflectors to shield the outer vessel wall such as proposed in the MOSART (Ignatiev et al., 2007) transuranic burner design. This graphite would likely require replacement, which removes much of the simplification advantage.

### 7.4. Pebble bed DMSR converter

Using graphite pebbles is a proposed change with great potential. The pebbles would be extremely simple to manufacture as they are only graphite and perhaps a pyrolytic coating. Simplification would also extend to overall core design since complicated top and bottom plenum spaces and the need to lock together graphite elements would not be required. Going to a higher power density and a smaller core is also now straight forward as replacing graphite is as simple as cycling out individual pebbles or shutting down briefly for batch pebble replacement. Oak Ridge always considered the use of pebbles as a strong candidate for breeder designs and many studies were performed on their use (Rosenthal et al., 1969, 1970). For example in one study (Rosenthal et al., 1970) with the pure Th- $^{233}\text{U}$  cycle, a simple pebble bed design without any attempt at an undermoderated outer zone and about the same fissile inventory did almost as good for a breeding ratio as the standard MSBR (1.03 versus 1.06). Oak Ridge was under heavy pressure to have as high a breeding ratio as possible, so pebble bed designs remained in the background despite their many advantages.

Having an undermoderated outer zone to limit the small losses of leakage neutrons is also still possible with pebble bed designs. For example in ORNL's designs it was often proposed to have a

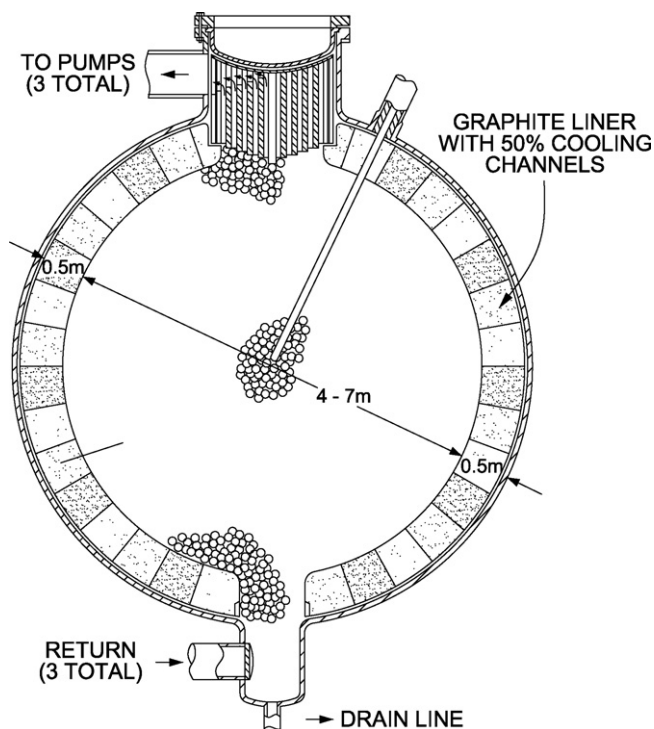

Fig. 6. An embodiment of a Pebble Bed DMSR Converter based on a modification of design work from ORNL 4344.

graphite liner/reflector around the pebble bed to limit neutron flux at the outer vessel. This liner can be simply modified to be an under-moderated neutron absorbing zone, for instance, having 50% of the liner volume as salt channels. Fig. 6 is a simple modification of an ORNL engineering drawing (Rosenthal et al., 1969) to show this proposed concept. Such an absorbing zone would mean smaller cores with higher power densities are possible without significant neutron leakage.

A random pebble bed does have a higher than ideal salt fraction of 37% but the same neutron spectrum can be obtained simply by having a lower fissile + fertile concentration in the salt to thus give similar carbon to fissile ratios. There will undoubtedly be an increase in the neutron losses to the salt but will have only a minor effect on uranium utilization.

In general, the technique of using an undermoderated outer region as proposed by ORNL works quite well in lowering neutron leakage even for quite small diameter cores. By using this technique it may prove optimal to switch any Single Fluid design (pebbles or graphite logs) to an elongated cylinder geometry, without increasing neutron leakage significantly. There are numerous advantages to a longer, slender core. For one, top and bottom plenum spaces where core salts collect are a challenge to design and take up a large relative volume of salt. This would be minimized in a slender core. Fabrication of a long slender vessel would also be simpler. Finally, this might introduce new possibilities of in-situ decay heat management if no part of the core was too far from the outer vessel wall. Decay heat could flow by conduction through the graphite and salt in a manner similar to TRISO fueled PBMR or prismatic core designs. Decay heat removal is typically done by the passive draining to dump tanks but this may offer an interesting alternative.

### 7.5. Alternate carrier salt DMSR converter

Another simple concept but of perhaps great importance would be to utilize an alternate carrier salt instead of the standard flibe ( ${}^7\text{LiF}\text{-BeF}_2$ ). Flibe carrier salts are neutronically superior but the enriched lithium and beryllium are expensive, beryllium is toxic

and they both lead to small but significant production of tritium (roughly equivalent to that of CANDU Reactors). Managing tritium, which can diffuse through hot metal walls of heat exchangers, was always a significant part of ORNL's work on these systems. Their choice of intermediate coolant salt ( $\text{NaF}\text{-NaBF}_2$ ) was made in part to trap tritium and in general, while certainly not a show stopper, tritium has always been a source of concern. It should be mentioned that gas Brayton cycles are often now assumed the best fit to molten salt reactors and these offer still further advantages for tritium management because any tritium making it to the gas is far easier to remove than from steam. Steam cycles however represent an attractive "off the shelf" option, especially with the newest Ultra SuperCritical cycles that could approach 50% efficiency if coupled to molten salt reactors.

There are several carrier salt candidates that do not require either  ${}^7\text{Li}$  or  $\text{Be}$  with an obvious choice being the very first salt used in the Aircraft Reactor Experiment,  $\text{NaF}\text{-ZrF}_4\text{-(U,Th)F}_4$ . Other possibilities include  $\text{NaF}\text{-RbF}\text{-(Th,U)F}_4$ ,  $\text{RbF}\text{-ZrF}_4\text{-(U,Th)F}_4$ ,  $\text{NaF}\text{-(Th,U)F}_4$  although the later has a somewhat high melting point. There are also many interesting choices that at least remove the need for enriched lithium, the most likely choice being  $\text{NaF}\text{-BeF}_2\text{-(Th,U)F}_4$ .

There has been much recent examination of  $\text{NaF}\text{-ZrF}_4$  as a carrier salt in transuranic waste burners. In those studies (Greenspan et al., 2002) criticality was difficult to maintain due to the limited solubility of  $\text{PuF}_3$ . Carrier salts can typically carry 10 times more U and/or Th so reaching criticality for a LEU converter design is not a problem. There is also a higher solubility for  $\text{PuF}_3$  and any rare earth trifluorides when  $\text{UF}_4$  or  $\text{ThF}_4$  is present (Ward et al., 1960). This is important for converter designs in which trifluoride fission products build up with time.

In various studies such as with  $\text{NaF}\text{-ZrF}_4$  (Greenspan et al., 2002) or  $\text{LiF}\text{-NaF}\text{-BeF}_2$  (Ignatiev et al., 2007) or  ${}^7\text{LiF}\text{-NaF}\text{-(Th,U)F}_4$  (Nuttin, 2002) the increased neutron losses relative to flibe are not excessive. Based on these studies, the non-tritium producing salts in a graphite moderated design might be expected to see 2–3 times the losses of neutrons to the carrier salt as compared to flibe. In fact, if the carrier salt has a significantly higher concentration of LEU + Th than the 9.5% proposed for the DMSR, then a far lower salt volume percentage is needed in core. In this case, some salt alternatives could perhaps do as well or better than flibe. In ORNL's DMSR converter design, neutron losses to salt were only 1.53% so even if losses were a worst case of 5 times higher, the average conversion ratio would drop from 0.8 to about 0.67 and still require less than a third the annual uranium ore needs of an LWR. At a natural uranium cost of 100\$/kg the annual LEU fuel costs (Moir, 2007), including enrichment, would only be 10.5 million (5 for ore, 5.5 enrichment) per GW(e)year (0.29% tails, 110\$/kgSWU) for this worst case. Even natural uranium at 1000\$/kg gives only 56 million which is roughly current LWR fuel costs including fabrication. Such estimates of neutron losses and associated uranium utilization are obviously only crude estimates.

### 7.6. An LEU only DMSR converter

As briefly discussed in Section 7.2, operation on LEU alone without thorium is an interesting possible option. A disadvantage is that it removes the fraction of fissions coming from the neutron rich  $\text{Th}\text{-}{}^{233}\text{U}$  cycle. In the traditional DMSR core and looking at the 15 year mid point, the weighted average of  $\eta$  (neutrons per fissile absorption) is 1.95 for  ${}^{235}\text{U} + {}^{239}\text{Pu} + {}^{241}\text{Pu}$  while  ${}^{233}\text{U}$  alone is 2.24. This gives an overall average  $\eta$  of 2.10 (weighted by fission fraction). If operation would be on LEU alone then the average  $\eta$  should drop down to about 1.95 which suggests a roughly 0.15 drop in conversion ratio (0.8–0.65). However both options would start with roughly the same conversion ratio of 0.8 (both start with  ${}^{235}\text{U}$  as the only fissile with an  $\eta$  of 1.99). For the LEU + Th case, the conver-

sion ratio rises over the first several years due to  $^{233}\text{U}$  production, then drops as fission products build up. For LEU alone, it would start around 0.8 and drop slowly as fission products build up. The long term average conversion ratio for LEU only should thus be close to 0.7 whereas with shorter batch cycles this could be closer to 0.75. This means the penalty to uranium utilization is smaller than one might at first suspect.

Running on LEU alone opens up some unique advantages that may not have been examined in the past. First, while  $\text{UF}_4$  and  $\text{ThF}_4$  tend to behave similarly in carrier salt eutectics, salt mixes with only  $\text{UF}_4$  typically have lower melting points or conversely, allow higher  $\text{UF}_4$  concentrations and still remain below the traditional  $525^\circ\text{C}$  melting point limit for use with Hastelloy N. Second, without thorium (or only having small amounts) means the core design is no longer constrained regarding limiting neutron losses to  $^{233}\text{Pa}$ . This means that the power density can be increased greatly (lowering the start-up fissile inventory) and there is no longer a constraint to have a more thermalized neutron spectrum (as previously reviewed, the DMSR is a softer spectrum than the MSBR to lower neutron losses to Pa). It should be mentioned though that there are still advantages to a quite well thermalized spectrum though since  $\eta$  for  $^{239}\text{Pu}$  and  $^{235}\text{U}$  are somewhat better. As well, a soft spectrum means the absorption and fission cross sections for all Pu isotopes are larger which means it will stay at low concentrations which may prove important given the limited solubility of  $\text{PuF}_3$ .

Finally, in terms of proliferation resistance this design might represent the highest obtainable in any reactor design. There is no  $^{233}\text{Pa}$  present that could somehow be chemically separated to yield  $^{233}\text{U}$ . While plutonium is present and will need to be safeguarded, it will be of extremely low quality in terms of weapons used (much poorer than LWR spent fuel, etc.). The only window of opportunity for misuse would be in the first year or two of operation when the isotopic quality of the contained plutonium is more of a concern. This is easily countered however by simply starting all reactors using a mix of LEU and solid reactor spent fuel plutonium such that the plutonium present is always of very poor quality (and as always, very difficult to remove).

### 7.7. DMSR converter design summary

In general for DMSR converter designs, the potential does appear obvious for this under appreciated class of molten salt reactors. The pure  $\text{Th}-^{233}\text{U}$  cycle does lead to the ultimate in resource utilization but if simple converter designs can perform just as well in other categories and excel in overall cost, minimized R&D and proliferation resistance, it is only right they receive more attention. These simplified designs can also be looked upon as merely a 1st generation that can get up and running quickly with minimized R&D costs. Fuel processing capabilities or simple core changes can be made later to change to consuming thorium only. Again this hinges on the arguments around "Peak Uranium" but as shown in Table 2, even with a natural uranium price of \$5000/kg, operations would still be economical and open up virtually inexhaustible supplies, from numerous unconventional sources such as simple granite rock or sea water.

## 8. Summary

A goal of this report has been to show the great versatility and potential of molten salt designs. This may have come at the expense of appearing unfocused. With that in mind it would appear wise to put forth three designs considered to be leading candidates and to act as starting points for further modeling. A starting core power of 200 MW(e) appears an appropriate compromise between economy of scale and needs of component development costs (pumps, IHX, turbines, etc.).

Case 1 would be a  $\text{Th}-^{233}\text{U}$  cycle, graphite free, break even design of the simple tube within tube variation (LeBlanc, 2008) employing a metal barrier between core and blanket salts of either recently developed Hastelloy alloys or a high molybdenum alloy. The later being more difficult to fabricate but likely having a much longer in core service life. To break even on breeding, a fissile concentration of about 0.3%  $^{233}\text{UF}_4$  will likely be required which implies a tube diameter of about 85 cm and core length of 4 meters. At a  $200\text{ MW}/\text{m}^3$  power density this gives 450 MW(th) and 200 MW(e). The surrounding blanket salt would be 73%  $^7\text{LiF}-27\%\text{ThF}_4$  of about 1 m thickness and contained in an outer Hastelloy N vessel. Start-up fissile needs would be about 800 kg/GW(e) or 160 kg for one 200 MW(e) unit. Alternative start-up would be on LWR transuranics or by LEU as previously reviewed. Fission product processing of the fissile salt being by vacuum distillation on a 6 month cycle. The fertile salt would only receive periodic fluorinations to transfer produced  $^{233}\text{U}$  to the central fuel salt. At a small added expense, further processing to remove and recycle the minor amounts of Pu, Am and Cm from the fission products is likely desirable.

Case 2 would be a LEU+thorium converter reactor with only minor changes from Oak Ridge's design. The proposed changes that would appear to entail little added R&D would be a modestly higher ( $2\times$ ) power density and employing the alternate carrier salt 46%NaF–33%RbF–21%(U+Th) $\text{F}_4$  with a melting point under  $500^\circ\text{C}$ . Core size for 200 MW(e) and the modestly higher power density would be under 4 m width and height. This alternate carrier salt is inexpensive and produces no tritium but would require confirmation of adequate trifluoride solubility and compatibility with Hastelloy N (both likely). It should be mentioned that rubidium currently has almost no annual production but can be found as a by product of other alkaline metal mining (Williams, 2006).

A doubling of power density would mean graphite replacement every 12–15 years (11.25 full power years) but would substantially reduce the size and cost of the core along with the starting fissile inventory. Salt replacement at the same time appears wise with the removal and reuse of all uranium and likely all transuranics (Np, Pu, Am, Cm) into the subsequent batch. This salt choice has a much higher fissile concentration than in the DMSR study and thus a lower percentage of salt relative to graphite is employed. Thus it should do about as well on uranium utilization as the neutronically superior, but more voluminous,  $^7\text{LiF}-\text{BeF}_2$  carrier salt. Cost and rapid production potential of the NaF-RbF carrier salt would also see a large advantage over  $^7\text{LiF}-\text{BeF}_2$ .

Case 3 would be a pebble bed design employing an undermoderated outer zone to limit neutron leakage as discussed in Section 7.4. Fissile concentration in the carrier salt would be lowered by a factor of 3 to counter the tripling of salt fraction in a random pebble bed compared to the DMSR (0.37 vs. 0.13). This should result in a similar neutron spectrum. Again an alternate carrier salt is possibly an improvement and since the fissile/fertile concentration is low, more carrier salt choices are available, such as NaF-ZrF<sub>4</sub>, RbF-ZrF<sub>4</sub> or NaF-BeF<sub>2</sub>. As well, trifluoride solubility is of far lesser concern as fission products and  $\text{PuF}_3$  remain more diluted.

A 200 MW(e) version with three times the average power density of the DMSR would be a pebble bed core 3.9 m in diameter surrounded by an outer undermoderated zone of 0.5 m of solid graphite with 50% salt channels. Total salt volume would be  $26\text{ m}^3$  in the reactor with perhaps  $4\text{ m}^3$  out of core. This would result in a starting fissile inventory of about 350 kg  $^{235}\text{U}$  (as LEU). A shorter batch cycle time of about 5–7.5 full power years would give a similar fission product to fissile ratio profile as the DMSR. Uranium utilization will be slightly higher than the DMSR using flibe and

modestly higher still with an alternate carrier salt but still only a small fraction of LWR use.

For comparison, a 1000MW(e) version and the same 3 times average power density would be a pebble bed core of 6.6 m diameter or 7.6 m including the undermoderated zone. This would only require approximately 1100 kg of  $^{235}\text{U}$  for start-up (less than one-third than for the DMSR and one-fifth that of a LWR).

## 9. Conclusions

As is hopefully now evident, molten salt reactor designs offer great flexibility and advantages for any priorities one may set for advanced reactors. Overall power costs of the traditional Single Fluid Breeder design have been estimated to be lower by a small amount than LWR costs (Rosenthal et al., 1972; Moir, 2002; Moir and Teller, 2005), such that the great simplifications in design and fuel processing proposed here should lead to a clear advantage. Overall safety sees a multitude of advantages over other reactor designs and denatured operation or even LEU only designs can be employed if perceived proliferation issues of the pure  $\text{Th-}^{233}\text{U}$  cycle become an issue. Design and modeling work is ongoing by the author and others on these designs and numerous others giving the versatility to adapt to unforeseen design obstacles.

While at present, government and industry support is sorely lacking worldwide, the research and development needs (Forsberg, 2006b) are far less than many may imagine. Perhaps ORNL's greatest legacy in this respect has been their dedication to document all aspects of their work. This great wealth of technical information is now accessible at [www.ornl.gov/info/library](http://www.ornl.gov/info/library), or [www.energyfromthorium.com](http://www.energyfromthorium.com) and is being actively reexamined. While the lack of after sale profits in terms of solid fuel fabrication may require a different business model to attract corporate interest, the potential rewards are indeed great for any government, corporation or agency willing to take a leading role in this vital effort.

## References

- Alexander, L.G., et al., 1959. Nuclear characteristics of spherical, homogeneous, two-region, molten-fluoride-salt reactors. ORNL 2751.
- Bowman, C.D., August 1998. Once through thermal spectrum accelerator driven system for LWR waste destruction without reprocessing. Report ADNA 98-04.
- Cury, R., 2007. Etude metallurgique des alliages Ni-W et Ni-W-Cr: relation entre ordre a courte distance et durcissement. PhD Thesis Universite Paris XII. France.
- DiStefano, J.R., et al., March 1995. Materials considerations for molten salt accelerator-based plutonium conversion systems. ORNL/TM-12925/R1.
- Engel, J.R., et al., August 1978. Molten salt reactor for efficient nuclear fuel utilization without plutonium separation. ORNL-TM-6413.
- Engel, J.R., et al., July 1980. Conceptual design of a denatured molten salt reactor with once-through fueling. ORNL-TM-7207.
- Forsberg, C.W., 2006a. Developments in molten salt and liquid salt cooled reactors. Proceedings of the ICAPP.
- Forsberg, C.W., 2006b. Molten Salt Reactor Technology Gaps Proceedings of ICAPP.
- Furukawa, K., et al., 1990. Summary report: thorium molten-salt nuclear energy synergetics. J. Nucl. Sci. Technol. 27, 1155–1178.
- Furukawa, K., 1992. The Combined System of Accelerator Molten-Salt Breeder (AMSB) and Molten-Salt Converter Reactor (MSCR). Japan-US Seminar on Th Fuel Reactors, Nara.
- Furukawa, K., et al., 2008. A road map for the realization of global-scale thorium breeding fuel cycle by single molten-fluoride flow. Energy Conv. Manag. 49, 1832–1848.
- Gat, U., et al., 1992. Molten Salt Reactors for Burning Dismantled Weapons Fuel. Nuc. Tech. 100 (3), 390–394.
- Gat, U., et al., 1997. Molten Salt Reactors—safety options galore. In: Proc. of an International ANS Topical Meeting on Advanced Reactor Safety, Orlando FL.
- Greenspan, E., et al., 2002. Optimization of a Molten Salt Transmuter Reactor. PHYSOR, Seoul, Korea.
- Greenspan, E., et al., 2007. Transmutation performance of Molten Salt versus solid fuel reactors. In: 15th Int. Conf on Nuclear Engineering, Nagoya Japan ICONE15.
- Ignatiev, V., et al., 2007. Progress in Development of Li, Be, Na/F Molten Salt Actinide Recycler and Transmuter Concept. Proceedings of the ICAPP 2007.
- Keiser, J.R., et al., April 1977. The Corrosion of Type 316 Stainless Steel to  $\text{Li}_2\text{BeF}_4$ . ORNL-TM-5782.
- Koger, J.W., December 1972. Alloy Compatibility with  $\text{LiF-BeF}_2$  Salts Containing  $\text{ThF}_4$  and  $\text{UF}_4$ . ORNL-TM-4286.
- LeBlanc, D., May 2008. Molten Salt Nuclear Reactor. U.S. Patent Application, Ser 12/118,118.
- Lecarpentier, D., 2001. Le Concept AMSTER, Aspects Physiques et Surete. Ministere de l'Education National—Conservatoire National des Arts et metiers. Ph.D Thesis.
- MacPherson, H.G., et al., 1958. Molten Salt Program Quarterly Progress Report ORNL 2551.
- McNeese, L.E., February 1971. Engineering Development Studies for Molten Salt Breeder Reactor Processing, No. 2. ORNL-TM-3137.
- Merle-Lucotte, E., et al., 2007a. Optimized transition from the reactors of second and third generation to the Thorium Molten Salt Reactor. Proceedings of the ICAPP 2007.
- Merle-Lucotte, E., 2007b. Introduction to the physics of molten salt reactors in Materials Issues for Generation IV Systems. Status, open questions and challenges. NATO Advanced Study Institute on Materials for Generation IV Nuclear Reactors (MATGEN-IV), France.
- Merle-Lucotte, E., 2008a. Optimization and simplification of the concept of non-moderated Thorium Molten Salt Reactor. In: International Conference on the Physics of Reactors PHYSOR.
- Merle-Lucotte, E., 2008b. Le Cycle Thorium en Reacteurs A Sels Fondus Peut-il Etre Une Solution au Problem Energetique du XXI<sup>eme</sup> Siecle? Le Concept de TMSR-NM. d'Habilitation a Diriger les Rechrs de L'Institute Polytechnique de Grenoble.
- Mourougov, A., Bokov, P.M., 2005. Potentialities of the Fast Spectrum Molten Salt Reactor Concept: REBUS-3700. ICENES'2005, Brussels.
- Moir, R.W., 2002. Cost of Electricity from Molten Salt Reactors. Nucl. Technol. 138, 93.
- Moir, R.W., Teller, E., 2005. Thorium fueled underground power plant based on molten salt technology. Nucl. Technol. 151, 334.
- Moir, R.W., 2007. Recommendations for a Restart of Molten Salt Development. ICENES2007, Istanbul.
- Nuttin, A., 2002. Potentialités du concept de réacteur à sels fondus pour une production durable d'énergie nucléaire basee sur le cycle thorium en spectre epithermique. Ph.D Thesis. L'Universite Joseph Fourier-Gernoble I.
- Peterson, P., et al., 2008. Design, Analysis and Development of the Modular PB-AHTR. ICAPP' 08, Anaheim CA.
- Robertson, R.C., et al., August 1970. Two-Fluid Molten Salt Breeder Reactor Design Study (Status as of Jan 1, 1968). ORNL 4528.
- Rosenthal, M.W., et al., February 1969. Molten Salt Reactor Program Semiannual Progress Report. ORNL-4344.
- Rosenthal, M.W., et al., August 1970. Molten Salt Reactor Program Semiannual Progress Report. ORNL-4548.
- Rosenthal, M.W., et al., August 1972. Molten Salt Reactor Program The Development Status of Molten Salt Breeder Reactors. ORNL-4812.
- Scott, C.D., et al., January 1966. Preliminary design study of continuous fluorination-vacuum-distillation system for regenerating fuel and fertile streams in a molten salt breeder reactor. ORNL 3791.
- Shaw, M., September 1972. U.S. Atomic Energy Commission An Evaluation of the Molten Salt Breeder Reactor. U.S. Atomic Energy Commission, WASH 1222.
- Sorensen, K., 2007. Private Communication.
- Ward, W.T., et al., 1960. Rare earth and yttrium fluorides: solubility relations in various molten  $\text{NaF-ZrF}_4$  and  $\text{NaF-ZrF}_4\text{-UF}_4$  solvents. J. Chem. Eng. Data 5 (2), 137–142.
- Weinberg, A.M., et al., 1970. Entire volume on molten salt breeder reactor. Nuc. App. Tech. 8 (February).
- Williams, D.F., March 2006. Assessment of Candidate Molten Salt Coolants for the Advanced High Temperature Reactor (AHTR). ORNL/TM-2006/12.
- Zinkle, S.J., Ghoniem, N.M., 2000. Operating windows for fusion reactor structural materials. Fusion Eng. Des. 51–52, 55–71.